

V

THE INFORMATION CONTAINED HEREIN IS UNCLASSIFIED EXCEPT WHERE SHOWN OTHERWISE. ALL RIGHTS RESERVED. FOR THE RECORD, THIS DOCUMENT IS THE PROPERTY OF THE COMPANY AND IS LOANED TO YOUR ORGANIZATION. IT IS TO BE RETURNED TO THE COMPANY UPON REQUEST.

REV	DESCRIPTION	DATE	APPROVED
A	INITIAL RELEASE OF SERVICES PRE-PRODUCTION DRAWING FJ5985-1010S REV "NONE" (1) ADDED "(2 REQUIRED)"	1999-08-12 JJB	EN-F19170 DP-1256

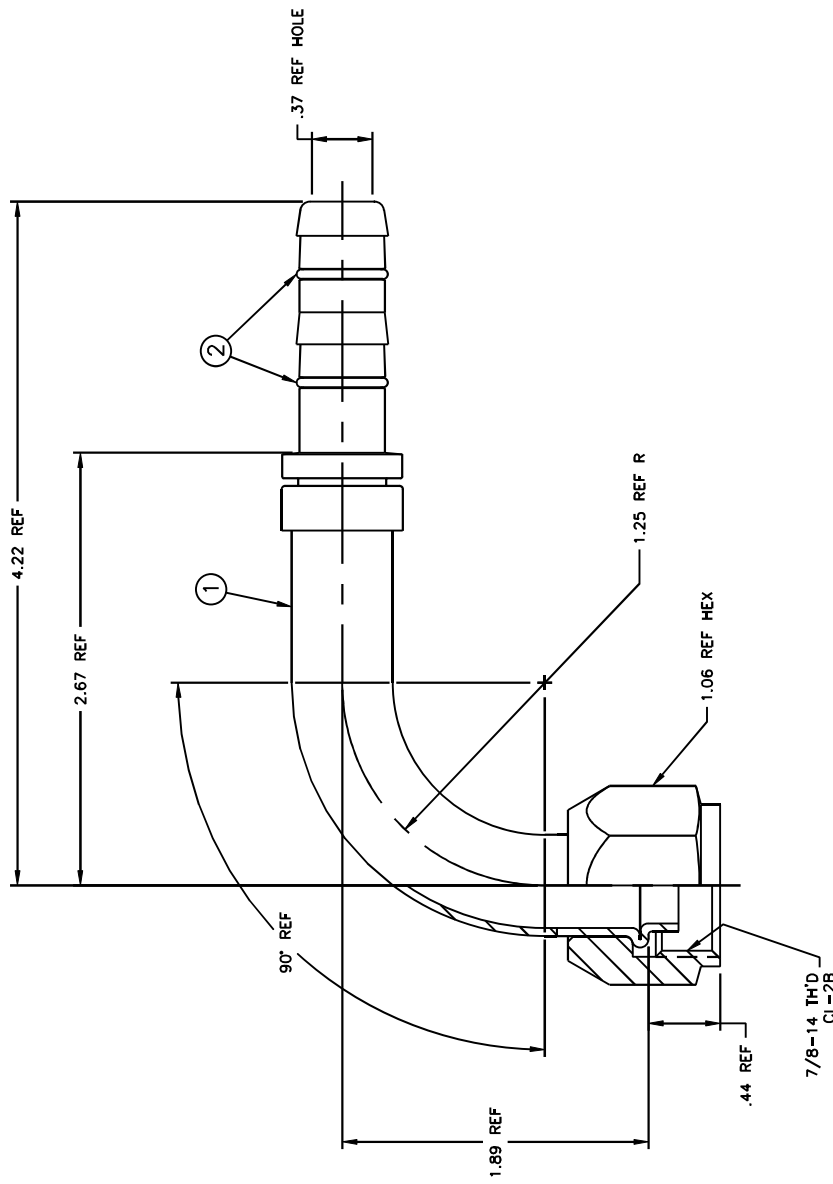

EDM

GROUP PART NUMBER	FJ4985-1010S	1F40106-10	O-RING
1	ASSEMBLY	2	(2 REQUIRED)

ITEM NO.	MATERIAL	LIST OF MATERIALS
1	STEEL	Drawn: J. HARTFORD Checked: J. BANNISEN Approved: J. GRAU Release Date: 1999-08-25 EN-F19170 DP-1256
2	HNBR	Drawn: J. HARTFORD Checked: J. BANNISEN Approved: J. GRAU Release Date: 1999-08-25 EN-F19170 DP-1256

1. PROCESS AS FOLLOWS:
(a) LUBRICATE O-RINGS AND ASSEMBLE ON NIPPLE AS SHOWN.

REV	A	DATE	1999-08-12	APPROVED	JJB
DESCRIPTION	INITIAL RELEASE OF SERVICES PRE-PRODUCTION DRAWING FJ5985-1010S REV "NONE" (1) ADDED "(2 REQUIRED)"				
GROUP PART NUMBER	FJ5985-1010S	1F40106-10	O-RING	(2 REQUIRED)	
ITEM NO.	1	ASSEMBLY	2	(2 REQUIRED)	
MATERIAL	STEEL				
	HNBR				
SCALE	2/1	DWG NO.	FJ5985-1010S	SHEET NO.	A
DATE	1999-08-12	APP'D	JJB	CHECKED	JJB
ENGIN					

DWG NO. FJ5985-1010S

