

| REVISIONS | | | |
|-----------|-------------|------|----------|
| REV | DESCRIPTION | DATE | APPROVED |
| | | | |

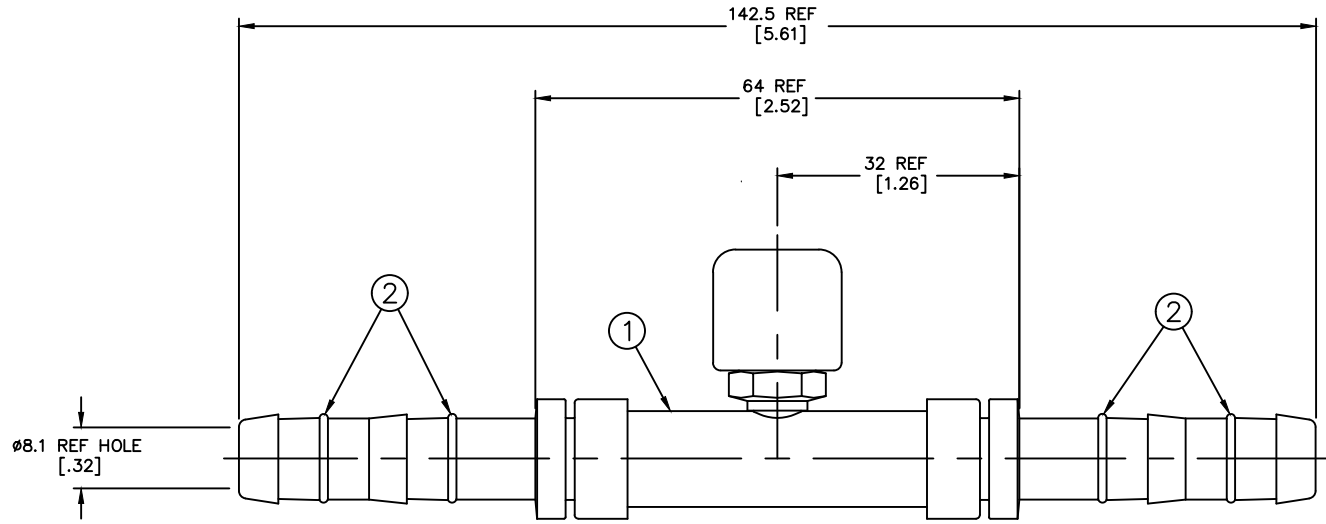

METRIC

- 2. DIMENSIONS ARE IN MILLIMETERS [INCHES].
- 1. PROCESS AS FOLLOWS:
(a) LUBRICATE O'RINGS AND ASSEMBLE TO NIPPLES AS SHOWN.

| | | | | |
|----------------------|-------------------|----------------------------|--|--------------------------------|
| FJ3171-0808S | FJ2171-0808S | 1F40106-08 | | |
| AEROQUIP PART NUMBER | ① NIPPLE ASSEMBLY | ② O'RING (4 REQ'D) | | |
| LIST OF MATERIALS | | | | |
| ITEM NO. | MATERIAL | DRAWN R. KELLY | FLUID CONVEYANCE DIVISION DRAWING TITLE FITTING ASSEMBLY SPLICER WITH R12 CHARGE PORT, GH134 HOSE | |
| 1 | STEEL | CHECKED R. D. WEBB | | |
| 2 | HNBR | APPROVED R.D.GARRETT | | |
| | | RELEASE DATE 2000-07-24 | | |
| | | EN-F20160 | SIZE A2 | DRAWING NUMBER FJ3171-0808S |
| | | DP-1256 | SCALE 2/1 | DIST U |
| | | THIRD ANGLE PROJECTION | CAGE CODE 01276 | SHEET |
| | | ITEM TYPE TZA | | |

DWG. NO. FJ3171-0808S SH. REV. EN