

THE REPRODUCTION, DISTRIBUTION AND UTILIZATION OF THIS DOCUMENT, AS WELL AS THE COMMUNICATION OF ITS CONTENTS TO OTHERS WITHOUT EXPLICIT AUTHORIZATION IS PROHIBITED. OFFENDERS WILL BE HELD LIABLE FOR THE PAYMENT OF DAMAGES. ALL RIGHTS RESERVED IN THE EVENT OF THE GRANT OF A PATENT, UTILITY MODEL OR DESIGN. (PER ISO 18016)

REVISIONS			
REV	DESCRIPTION	DATE	APPROVED
A	(1) 1.35 REF WAS 1.55 REF DIMENSIONED FROM OPPOSITE END OF NIPPLE (2) ADDED .70 REF DIMENSION (3) "NIPPLE" WAS "NIPPLE ASSEMBLY"	1999-10-04 R.D.G.	EN-F19366 DP-24901

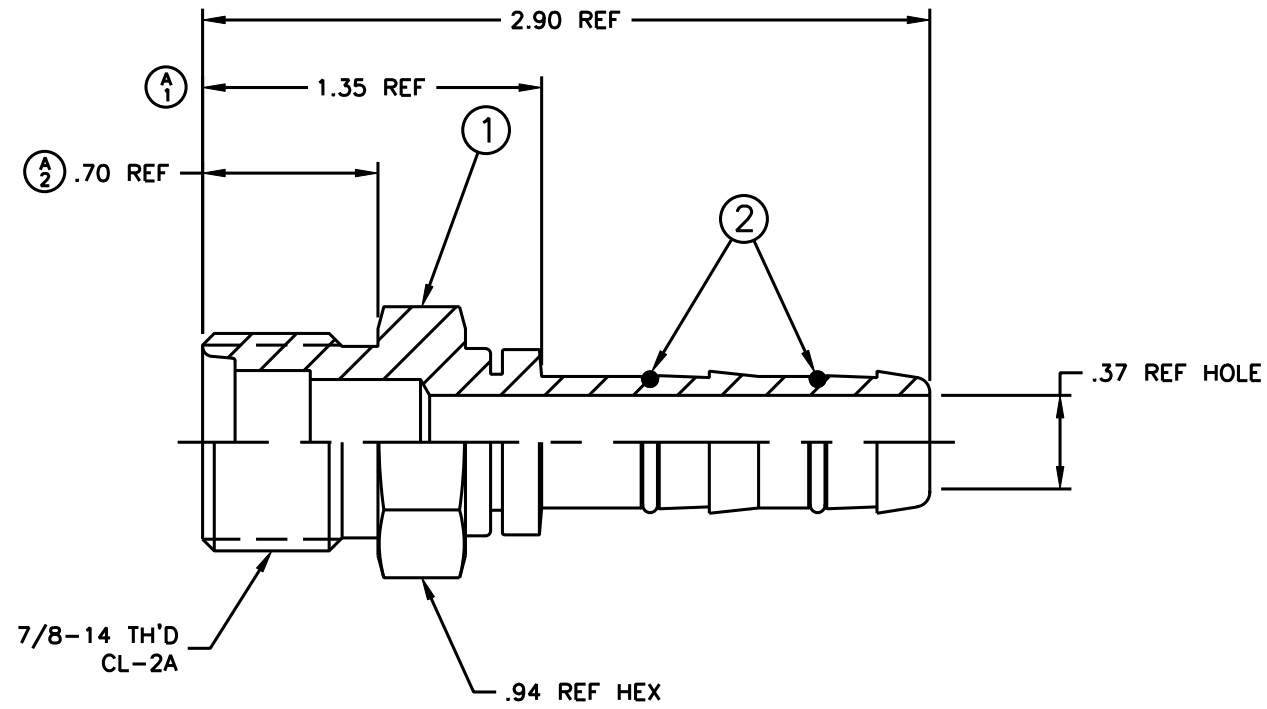

INCH

FJ3026-1010S	FW1213-1010S	1F40106-10		
AEROQUIP PART NUMBER	① NIPPLE	② O'RINGS (2 REQ'D)		
LIST OF MATERIALS				
ITEM NO.	MATERIAL	DRAWN	DRAWING TITLE	
1	STEEL	R ICKES	FLUID CONVEYANCE DIVISION FITTING ASSEMBLY MALE O'RING PILOT (LONG), A/C, GH134 HOSE	
2	HNBR	CHECKED J. BAHNSEN		
		APPROVED J. BAHNSEN		
		RELEASE DATE 1999-09-23		
		EN-F19184 RPS-5676		
		THIRD ANGLE PROJECTION	SIZE A2	DRAWING NUMBER FJ3026-1010
		ITEM TYPE: DTZA	SCALE 2/1	DIST U CAGE CODE 01276 SHEET NO

1. PROCESS AS FOLLOWS:
(o) LUBRICATE O'RINGS AND ASSEMBLE AS SHOWN.

FN

REV. A

SH.

FJ3026-1010

DWG. NO.