

SYM	REVISION	BY	DATE	ECN
A	ENGINEERING RELEASE	JS	3-11-92	21468

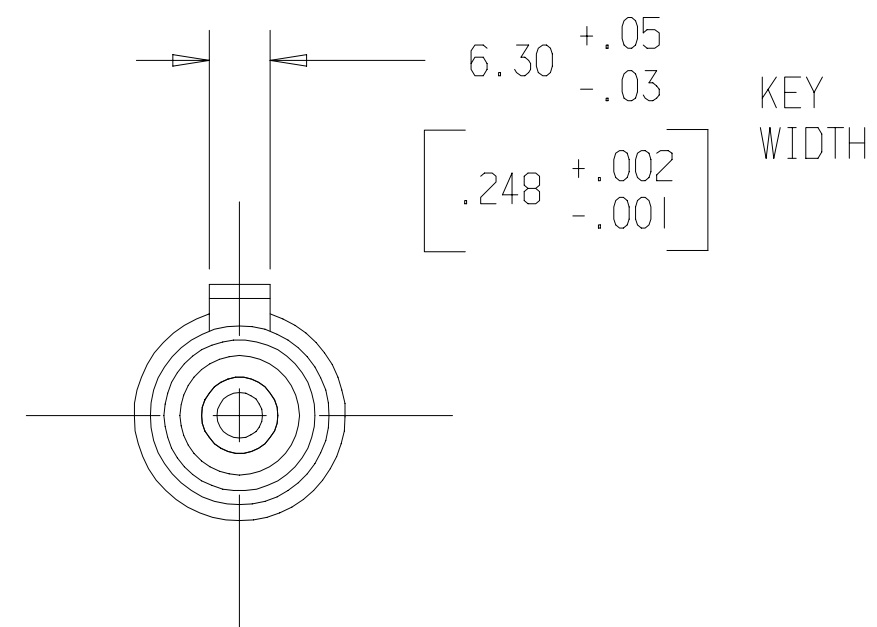
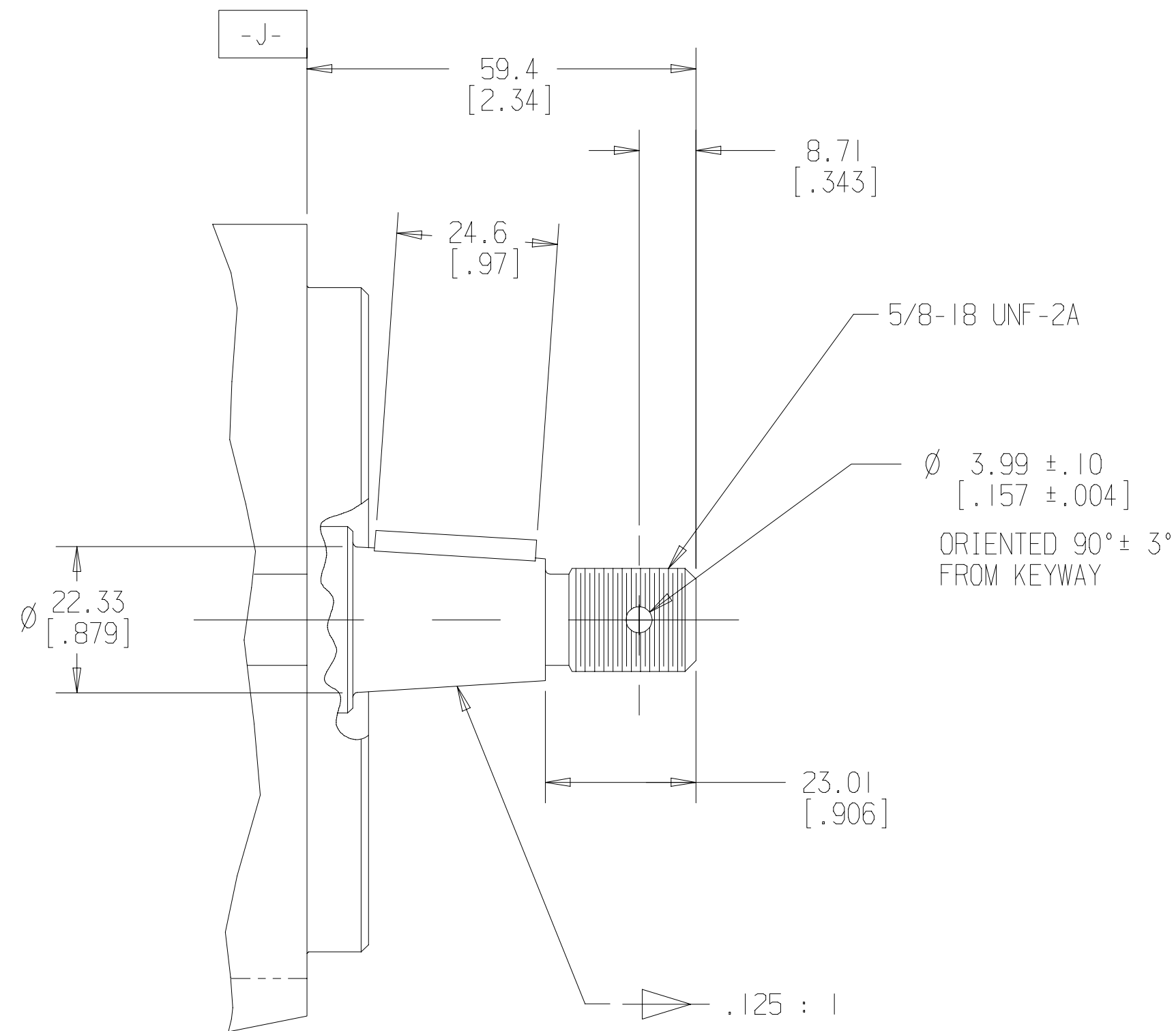

G HK

UNLESS OTHERWISE SPECIFIED ALL DIMENSIONS ARE IN INCHES <input type="checkbox"/> MILLIMETERS [INCHES] <input checked="" type="checkbox"/>	DRAWING BASED ON ANSI Y14.5M-1982	
	THE REPRODUCTION, DISTRIBUTION, AND UTILIZATION OF THIS DOCUMENT, AS WELL AS THE COMMUNICATION OF ITS CONTENTS TO OTHERS WITHOUT EXPLICIT AUTHORIZATION IS PROHIBITED. OFFENDERS WILL BE HELD LIABLE FOR THE PAYMENT OF DAMAGES. ALL RIGHTS RESERVED IN THE EVENT OF THE GRANT OF A PATENT, UTILITY MODEL, OR DESIGN. (PER ISO 16016)	
TOLERANCES .X $\pm$ .XX $\pm$ REF .XXX $\pm$ ANGLES $\pm$	DRAWN BY/DATE RLM 8/13/91 CHECKED BY/DATE ENGRG BY/DATE METALLURGY BY/DATE	MATERIAL/HEAT TREAT TITLE SHAFT INSTALLATION
UNSPECIFIED RADII ARE _____	THIRD ANGLE PROJECTION 	NUMBER A-290-061
UNSPECIFIED DRAFT ANGLES ARE _____	DO NOT SCALE	SCALE   /   SHEET   OF
DRAWING FORMAT CADD <input checked="" type="checkbox"/> MANUAL <input type="checkbox"/>		

*Danfoss*