

REV	DESCRIPTION	BY	CHK	DATE	ECN / MPS
A	RELEASE FOR SAMPLES AND ESTIMATES	EMR	EMR	2/03/03	M29924
C	ENGINEERING RELEASE	EMR	EMR	5/17/06	55727
D	REVISED	SDY	RLL	6/16/09	0017674
E	UPDATED PICTORIALY	MKS	KSJ	09/09/09	ECR-19389

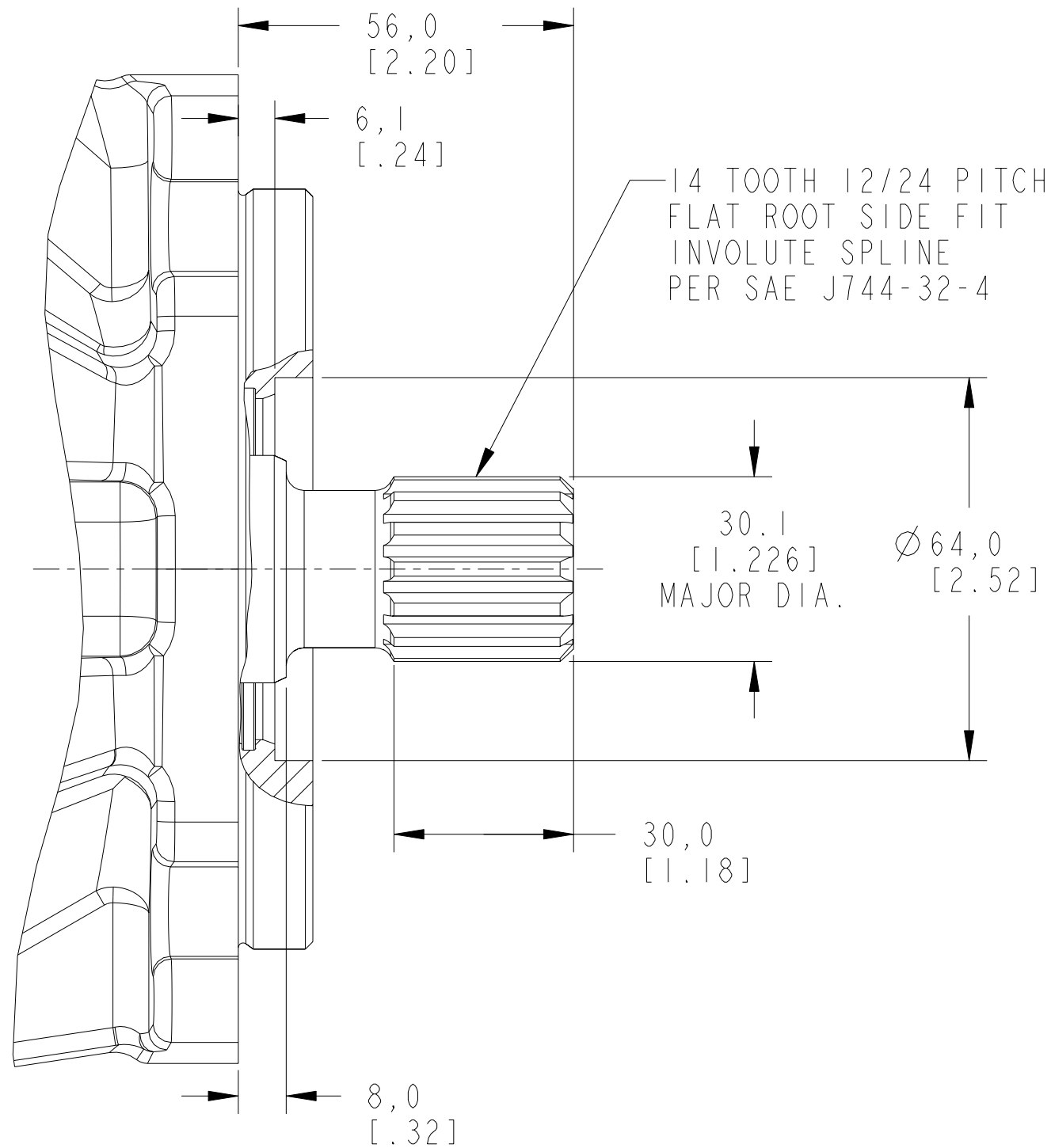

REVIEWED FOR CLASSIFICATION PER ESP-042

UNLESS OTHERWISE SPECIFIED ALL DIMENSIONS ARE IN INCHES <input type="checkbox"/> MILLIMETERS (INCHES) <input checked="" type="checkbox"/>	DRAWING BASED ON ANSI Y14.5M-1982	
	EATON CORPORATION - CONFIDENTIAL AND PROPRIETARY NOTICE TO PERSONS RECEIVING THIS DRAWING AND / OR TECHNICAL INFORMATION <small>THIS DOCUMENT, INCLUDING THE DRAWING AND INFORMATION CONTAINED THEREON, IS CONFIDENTIAL AND IS THE EXCLUSIVE PROPERTY OF EATON CORPORATION, AND IS MERELY ON LOAN AND SUBJECT TO RECALL BY EATON AT ANY TIME. BY TAKING POSSESSION OF THIS DOCUMENT, THE RECIPIENT ACKNOWLEDGES AND AGREES THAT THIS DOCUMENT CANNOT BE USED IN ANY MANNER ADVERSE TO THE INTERESTS OF EATON, AND THAT NO PORTION OF THIS DOCUMENT MAY BE COPIED OR OTHERWISE REPRODUCED WITHOUT THE PRIOR WRITTEN CONSENT OF EATON. IN THE CASE OF CONFLICTING CONTRACTUAL PROVISIONS, THIS NOTICE SHALL GOVERN THE STATUS OF THIS DOCUMENT. COPYRIGHT 2008 EATON CORPORATION - ALL RIGHTS RESERVED.</small>	
TOLERANCES .X ± ---- .XX ± ---- .XXX ± ---- < ± ----°	DRAWN EMR BY/DATE 5/14/04	MATERIAL/HEAT TREAT
	CHECKED EMR BY/DATE 5/11/05	TITLE
UNSPECIFIED RADII ARE: ----	ENGRG SP BY/DATE 5/11/05	INPUT SHAFT INSTALLATION, 620
UNSPECIFIED DRAFT ANGLES ARE: ----°	METALLURGY BY/DATE	NUMBER A-2492-001
B SIZE	THIRD ANGLE PROJECTION DO NOT SCALE	SCALE 1/1 SHEET 1 OF 1

