

REVISIONS			
REV	DESCRIPTION	DATE	APPROVED
C	INITIAL RELEASE, SUPERSEDES PRE-PRODUCTION PRINT 4SAI2FRC12_SHT1, REV. "B".	2014-09-25 JJS/DHS	0102552-ECO

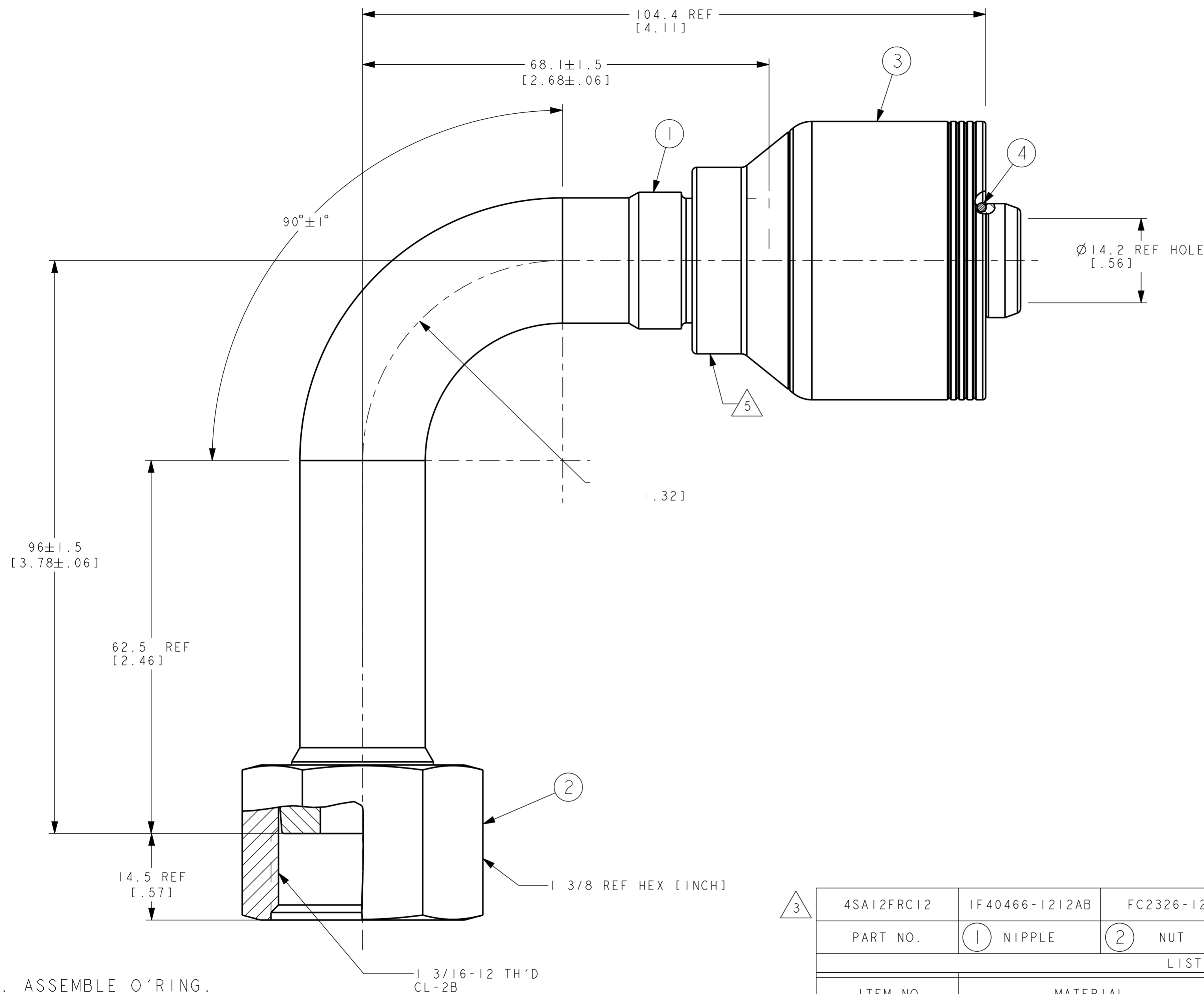

METRIC

- 6. ASSEMBLE O'RING.
- 5. CRIMP SOCKET PER ACES 2813.
- 4. ASSEMBLE NUT.
- 3. ZINC PLATE PER ES 2751.
- 2. BEND NIPPLE TO DIMENSIONS SHOWN.
- 1. DIMENSIONS ARE IN MILLIMETERS [INCHES].

3	4SAI2FRC12	IF40466-1212AB	FC2326-12S	4S12	FF91157-12
	PART NO.	1 NIPPLE	2 NUT	3 SOCKET	4 O'RING

LIST OF MATERIALS		DRAWN	
ITEM NO	MATERIAL	J. SONAVANE	
1	STEEL	CHECKED	
2	STEEL	D. SHEWALE	
3	STEEL	APPROVED	
4	EPDM	R. RUTSCHILLING	
		RELEASE DATE	
		2014-09-25	
		0102552-ECO	
		THIRD ANGLE PROJECTION	
		SCALE 2/1	DIST U
		CAGE CODE 01276	SHEET 1

Danfoss FLUID CONVEYANCE DIVISION

DRAWING TITLE
FITTING ASSEMBLY
 90°, ORS FEMALE SWIVEL
 4 WIRE SPIRAL HOSE

SIZE A2 DRAWING NUMBER 4SAI2FRC12 REV C

SCALE 2/1 DIST U CAGE CODE 01276 SHEET 1

THE REPRODUCTION, DISTRIBUTION AND UTILIZATION OF THIS DOCUMENT AS WELL AS THE COMMUNICATION OF ITS CONTENTS TO OTHER WITHOUT EXPLICIT AUTHORIZATION IS PROHIBITED. OFFENDERS WILL BE HELD LIABLE FOR THE PAYMENT OF DAMAGES. ALL RIGHT RESERVED IN THE EVENT OF THE GRANT OF A PATENT, UTILITY MODEL OR DESIGN. (PER ISO 16016)