

REV	DESCRIPTION	BY	CHK	DATE	ECN
A	ENGINEERING RELEASE	LMD	MLL	3-6-98	M19291
B	ADDED SECTION A-A	LMD	LMD	4-8-98	30993
C	-1)(6C)ADDED NOTE "H" ON BODY SECTION... -2)DELETED BOLT MARKINGS -3)UPDATED BACKPLATE	WSM	WSM	11/27/98	31483
D	-1)"PART IN KIT 9900205-000" WAS KIT 26000-901 -2)(3B)2X Ø11.56 [.455] WAS 2X Ø11.56 ±0.13 [.455±.005] -3)(2A)ADDED TORQUE TO ITEM 11 -4) (4C)ADDED SEAL DEPTH DIMENSION -5)(5D)ADDED "MARK SERIAL..." -6)(4D,3B)ADDED "DO NOT PAINT" -7)(4A)ADDED NOTE 1 -8)(4B,4C)ADDED HEX FLAG 1 TO ITEM 9 AND SEAL DEPTH DIMENSION -9)(2B) ADDED ESP-042 CLASSIFICATION	CEW	CEW	8-19-04	48858

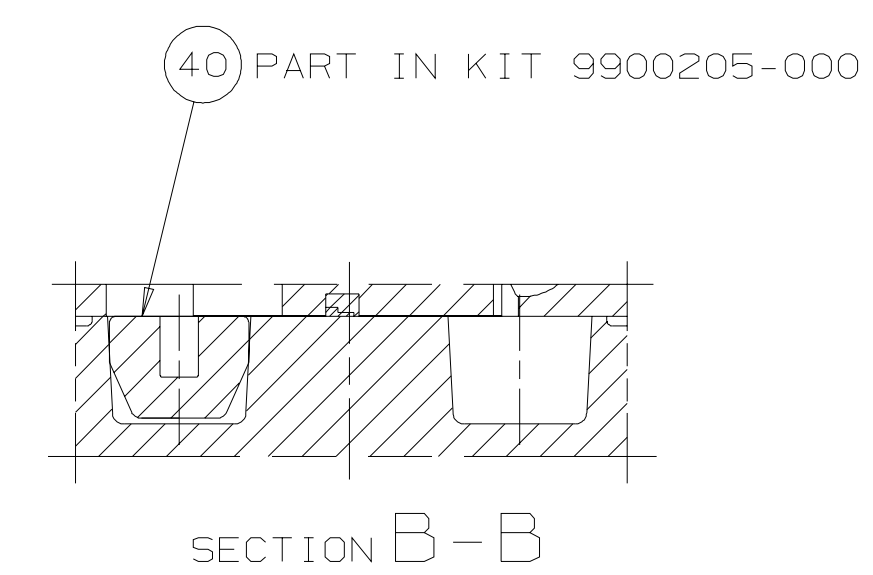

"H" ON BODY SECTION INDICATES  
HIGH PRESSURE SIDE OF PUMP

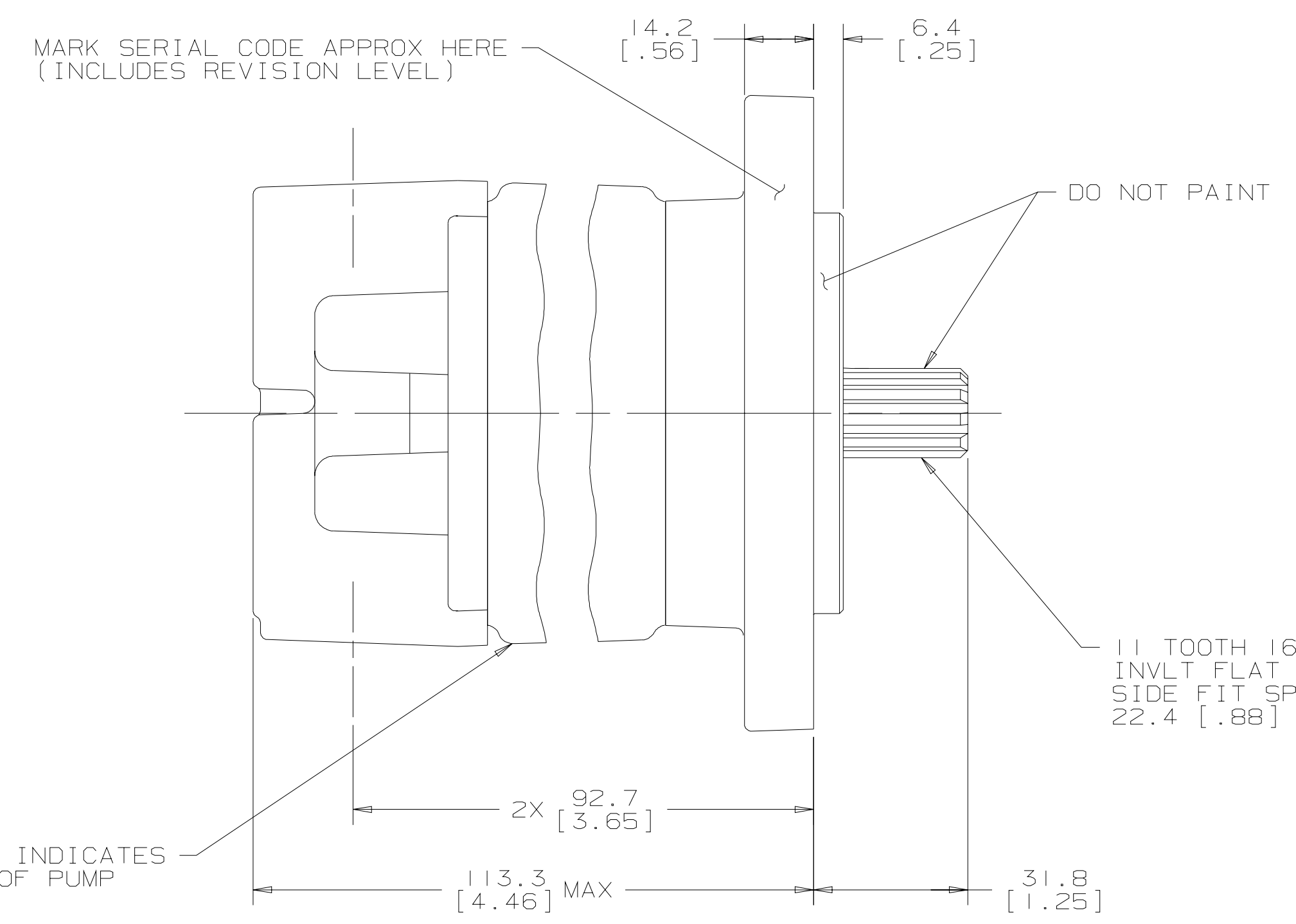
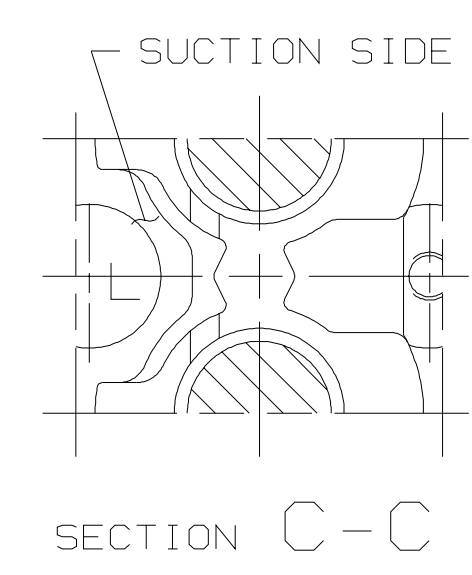
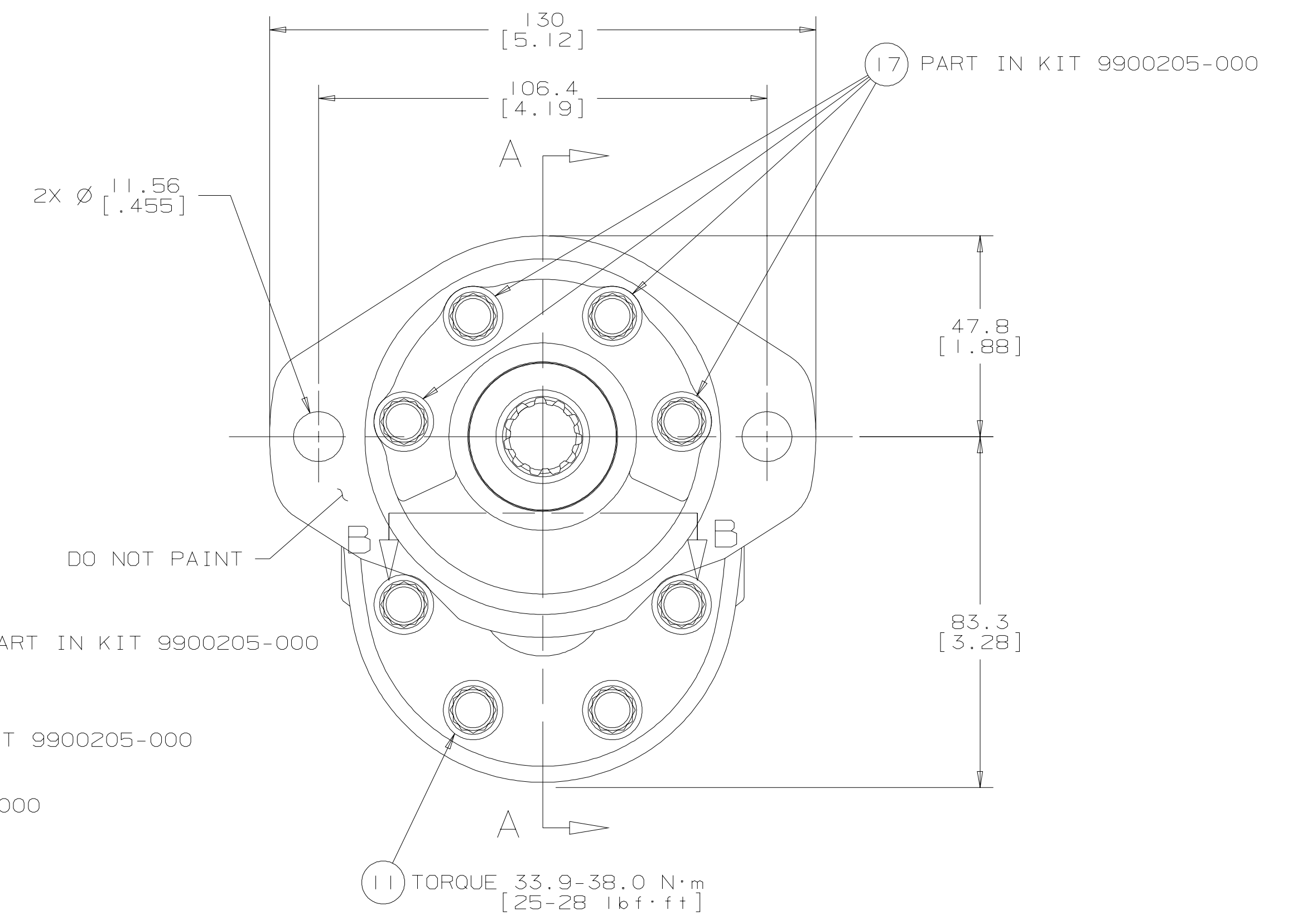
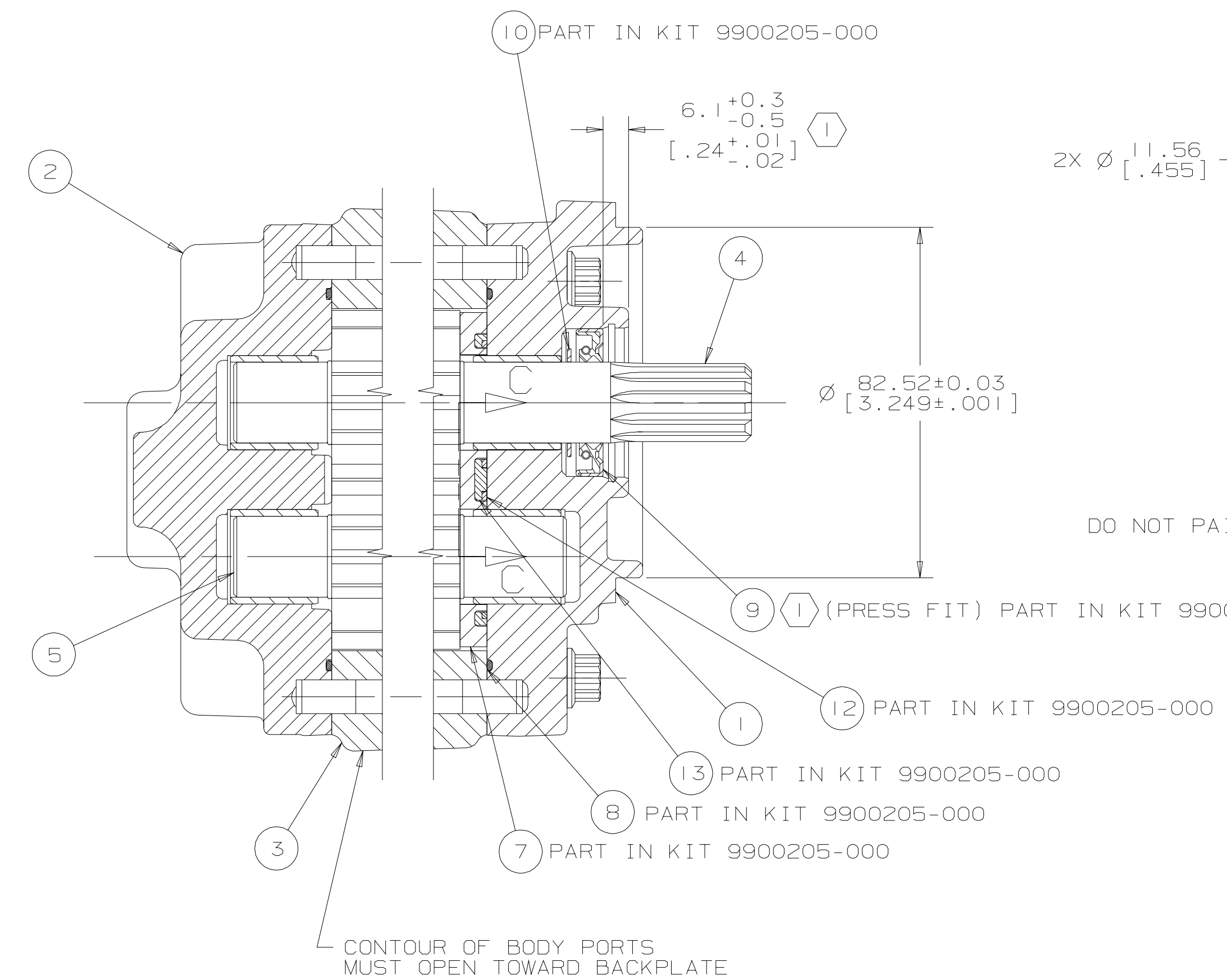
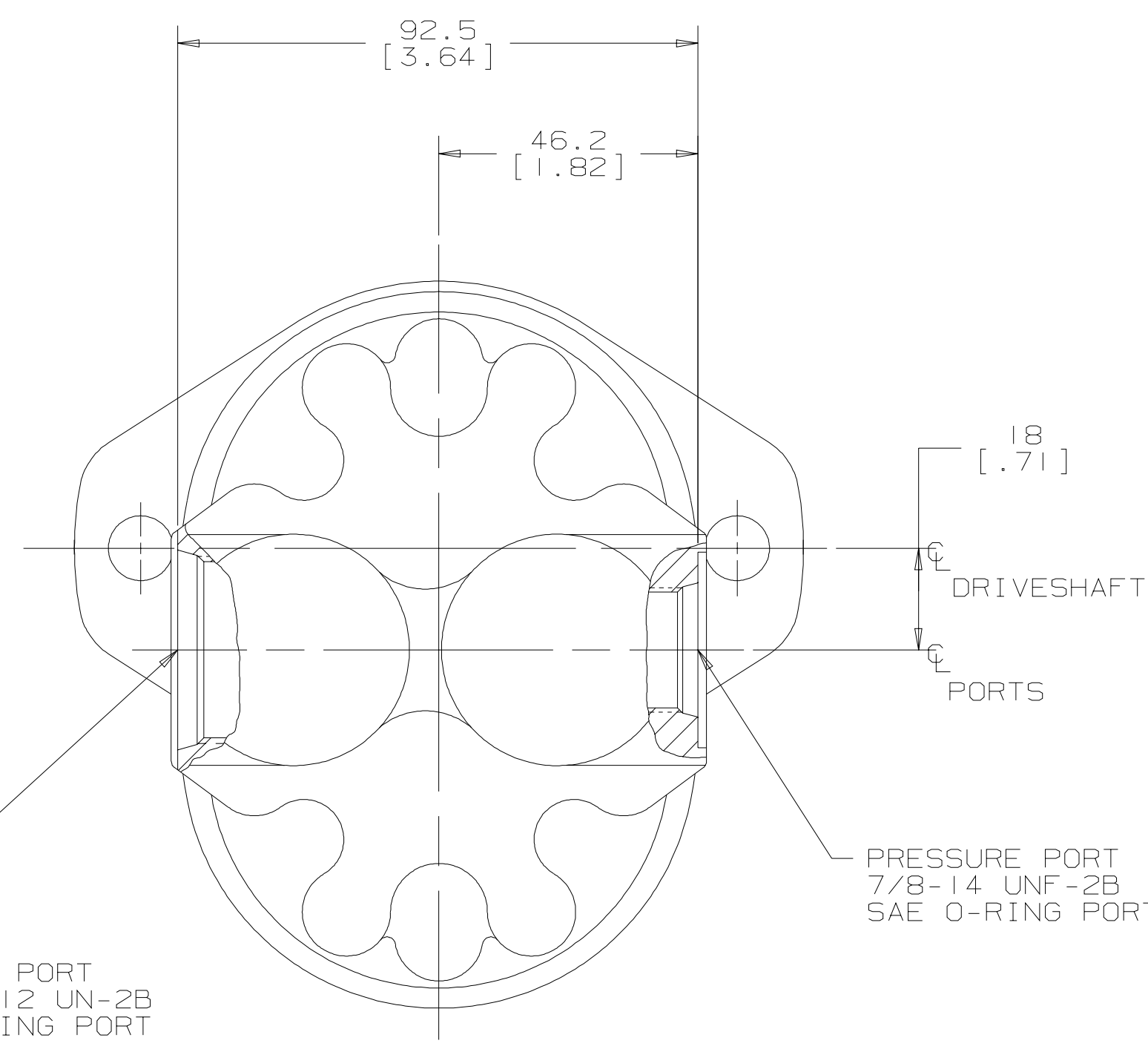

NOTE  
1 PRESS ITEM 9 SEAL TO DIMENSION SHOWN

REVIEWED FOR CLASSIFICATION PER ESP-042 G H

DRAWING BASED ON ANSI Y14.5M-1982

UNLESS OTHERWISE SPECIFIED ALL DIMENSIONS ARE IN:  
INCHES   
MILLIMETERS

TOLERANCES  
.xx ±REF  
.xxx ±ONLY  
±

UNSPECIFIED RADI ARE  
---

UNSPECIFIED DRAFT ANGLES ARE  
---

DRAWING FORMAT  
CADD  MANUAL

THE REPRODUCTION, DISTRIBUTION, AND UTILIZATION OF THIS DOCUMENT, AS WELL AS THE COMMUNICATION OF ITS CONTENTS TO OTHERS WITHOUT EXPLICIT AUTHORIZATION IS PROHIBITED. OFFENDERS WILL BE HELD LIABLE FOR THE PAYMENT OF DAMAGES. ALL RIGHTS RESERVED IN THE EVENT OF THE GRANT OF A PATENT, UTILITY MODEL, OR DESIGN. (PER ISO 16016)

DRWN BY/DATE LMD 3-11-98 MATERIAL/HEAT TREAT  
CHKD BY/DATE MLL 3-13-98  
ENGR BY/DATE JLY 3-13-98 TITLE  
METALLURGY -----

GEAR PUMP INSTALLATION

NUMBER  
26009-LAN

SCALE 1/1 SHEET 1 OF 1

Danfoss