

REVISIONS			
REV	DESCRIPTION	DATE	APPROVED
E	REDRAWN - SUPERSEDES 1SA-FJA-REV. "D" FOR 1SA10FJA10. (1) WAS 13.7 REF.	10-9-95	EN-F16023 DP-24900
F	(1) NOTE #1 (b) WAS - ZINC PLATE PER ACES 2751".	2020-05-28 AKG	CO-0203630

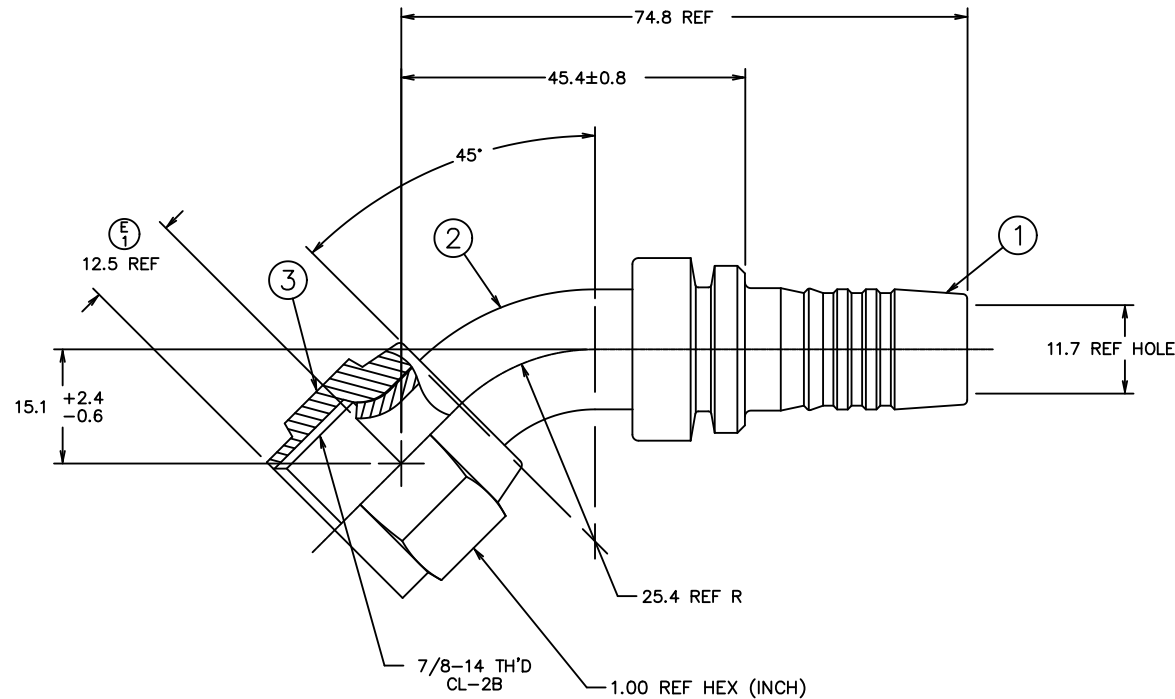

74.8	2.94
45.4±0.8	1.787±.031
25.4	1.00
15.1	+2.4
	-0.6
	.59
	+10
	-.02
12.5	.49
11.7	.46
MM	INCH

CONVERSION

METRIC

② CAN BE MADE FROM TUBING PER SPECIFICATIONS ON ELBOW DRAWING.

1. PROCESS AS FOLLOWS:

(a) BRAZE PER ACES 2814.

(b) ZINC PLATE PER ES 2751D8. ①

(c) ASSEMBLE NUT AND FLARE ELBOW PER FF481.

1SA10FJA10	1F40014-1010AB	1F40017-10-01AB	210221-10S					
AEROQUIP PART NUMBER	① NIPPLE	② ELBOW	③ NUT					
LIST OF MATERIALS								
ITEM NO.	MATERIAL	DRAWN K. PADGETT CHECKED R. GARRETT APPROVED R. GARRETT RELEASE DATE 2020-02-28 EN-F16023 DP-24900	FLUID CONVEYANCE DIVISION DRAWING TITLE NIPPLE ASSEMBLY 45°, SAE 37° SWIVEL 2781 HOSE					
1	STEEL	<table border="1"> <tr> <td>SIZE</td> <td>DRAWING NUMBER</td> <td>REV</td> </tr> <tr> <td>A2</td> <td>1SA10FJA10</td> <td>F</td> </tr> </table>	SIZE	DRAWING NUMBER	REV	A2	1SA10FJA10	F
SIZE	DRAWING NUMBER		REV					
A2	1SA10FJA10		F					
2	STEEL							
3	STEEL							
THIRD ANGLE PROJECTION		SCALE 2/1	DIST U					
		CAGE CODE 01276	SHEET 1					
THE REPRODUCTION, DISTRIBUTION AND UTILIZATION OF THIS DOCUMENT AS WELL AS THE COMMUNICATION OF ITS CONTENTS TO OTHERS WITHOUT EXPLICIT AUTHORIZATION IS PROHIBITED. OFFENDERS WILL BE HELD LIABLE FOR THE PAYMENT OF DAMAGES. ALL RIGHT RESERVED IN THE EVENT OF THE GRANT OF A PATENT, UTILITY MODEL OR DESIGN. (PER ISO 16016)								