

REV	DESCRIPTION	BY	DATE	ECN
A	ENGINEERING RELEASE	RAF	5/20/93	MI0742A
B	ADD SHAFT OPTION 28 TO NOTE 2	AGJ	5-26-93	22833
C	WAS 2 OUTPUT SHAFT: OPTION 04 & 28	MGF		32117
D	NOTE 1 WAS MOUNTING TYPE: OPTION J	AGJ	5-13-02	41044
E	52.6/50.5 [2.07/1.99] WAS 53.1/50.2 [2.09/1.98]	AGJ	5-17-04	47918
F	NOTE 2 WAS OUTPUT SHAFT: OPTION 02 & 24	PM	4-4-06	54522

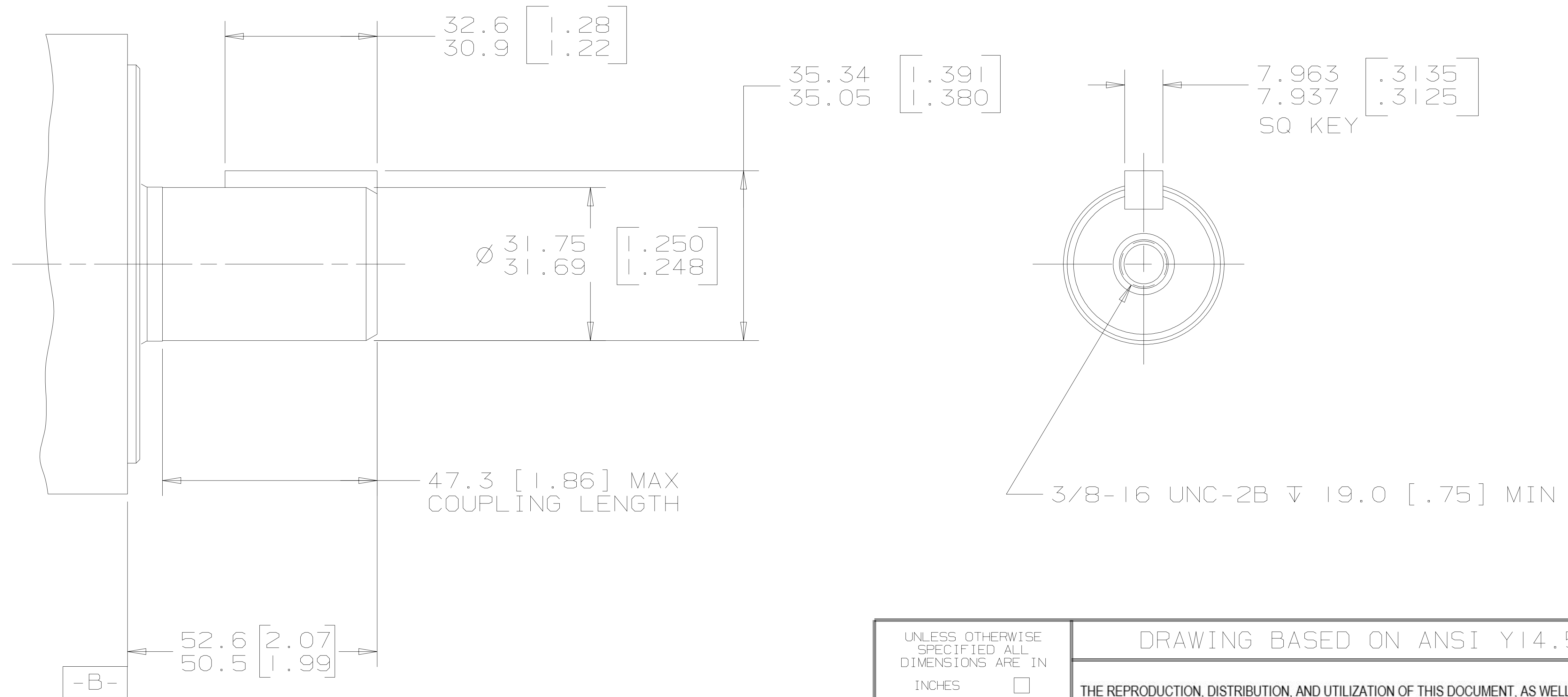

G K S

NOTE

- 1 MOUNTING TYPE: OPTION AJ
- 2 OUTPUT SHAFT: OPTION 02 & 17

UNLESS OTHERWISE SPECIFIED ALL DIMENSIONS ARE IN		DRAWING BASED ON ANSI Y14.5M-1982																	
INCHES <input type="checkbox"/>	MILLIMETERS [INCHES] <input checked="" type="checkbox"/>	THE REPRODUCTION, DISTRIBUTION, AND UTILIZATION OF THIS DOCUMENT, AS WELL AS THE COMMUNICATION OF ITS CONTENTS TO OTHERS WITHOUT EXPLICIT AUTHORIZATION IS PROHIBITED. OFFENDERS WILL BE HELD LIABLE FOR THE PAYMENT OF DAMAGES. ALL RIGHTS RESERVED IN THE EVENT OF THE GRANT OF A PATENT, UTILITY MODEL, OR DESIGN. (PER ISO 16016)																	
TOLERANCES		<table border="1"> <tr> <td>DRAWN BY/DATE</td> <td>RAF 5/21/93</td> <td>MATERIAL/HEAT TREAT</td> <td></td> </tr> <tr> <td>CHECKED BY/DATE</td> <td>K. RANDOLPH 5-21-93</td> <td>TITLE</td> <td>2000 SERIES MOTOR SHAFT INSTALLATION</td> </tr> <tr> <td>ENGRG BY/DATE</td> <td>S. ZUMBUSCH 5-21-93</td> <td>NUMBER</td> <td>A-688-002</td> </tr> <tr> <td>METALLURGY BY/DATE</td> <td>-----</td> <td>SCALE</td> <td>1/1</td> </tr> </table>		DRAWN BY/DATE	RAF 5/21/93	MATERIAL/HEAT TREAT		CHECKED BY/DATE	K. RANDOLPH 5-21-93	TITLE	2000 SERIES MOTOR SHAFT INSTALLATION	ENGRG BY/DATE	S. ZUMBUSCH 5-21-93	NUMBER	A-688-002	METALLURGY BY/DATE	-----	SCALE	1/1
DRAWN BY/DATE	RAF 5/21/93			MATERIAL/HEAT TREAT															
CHECKED BY/DATE	K. RANDOLPH 5-21-93	TITLE	2000 SERIES MOTOR SHAFT INSTALLATION																
ENGRG BY/DATE	S. ZUMBUSCH 5-21-93	NUMBER	A-688-002																
METALLURGY BY/DATE	-----	SCALE	1/1																
.X ±----	.XX ±REF	<table border="1"> <tr> <td>MICROINCHES <input type="checkbox"/></td> <td>ARITHMETICAL AVERAGE <input checked="" type="checkbox"/></td> <td>SHEET</td> <td>1 OF 1</td> </tr> </table>		MICROINCHES <input type="checkbox"/>	ARITHMETICAL AVERAGE <input checked="" type="checkbox"/>	SHEET	1 OF 1												
MICROINCHES <input type="checkbox"/>	ARITHMETICAL AVERAGE <input checked="" type="checkbox"/>	SHEET	1 OF 1																
.XXX ±ONLY	∠ ±----	<table border="1"> <tr> <td>THIRD ANGLE PROJECTION</td> <td>DO NOT SCALE</td> <td colspan="2"></td> </tr> </table>		THIRD ANGLE PROJECTION	DO NOT SCALE														
THIRD ANGLE PROJECTION	DO NOT SCALE																		
UNSPECIFIED RADII ARE -----	UNSPECIFIED DRAFT ANGLES ARE -----																		
DRAWING FORMAT CADD <input checked="" type="checkbox"/> MANUAL <input type="checkbox"/>																			

